

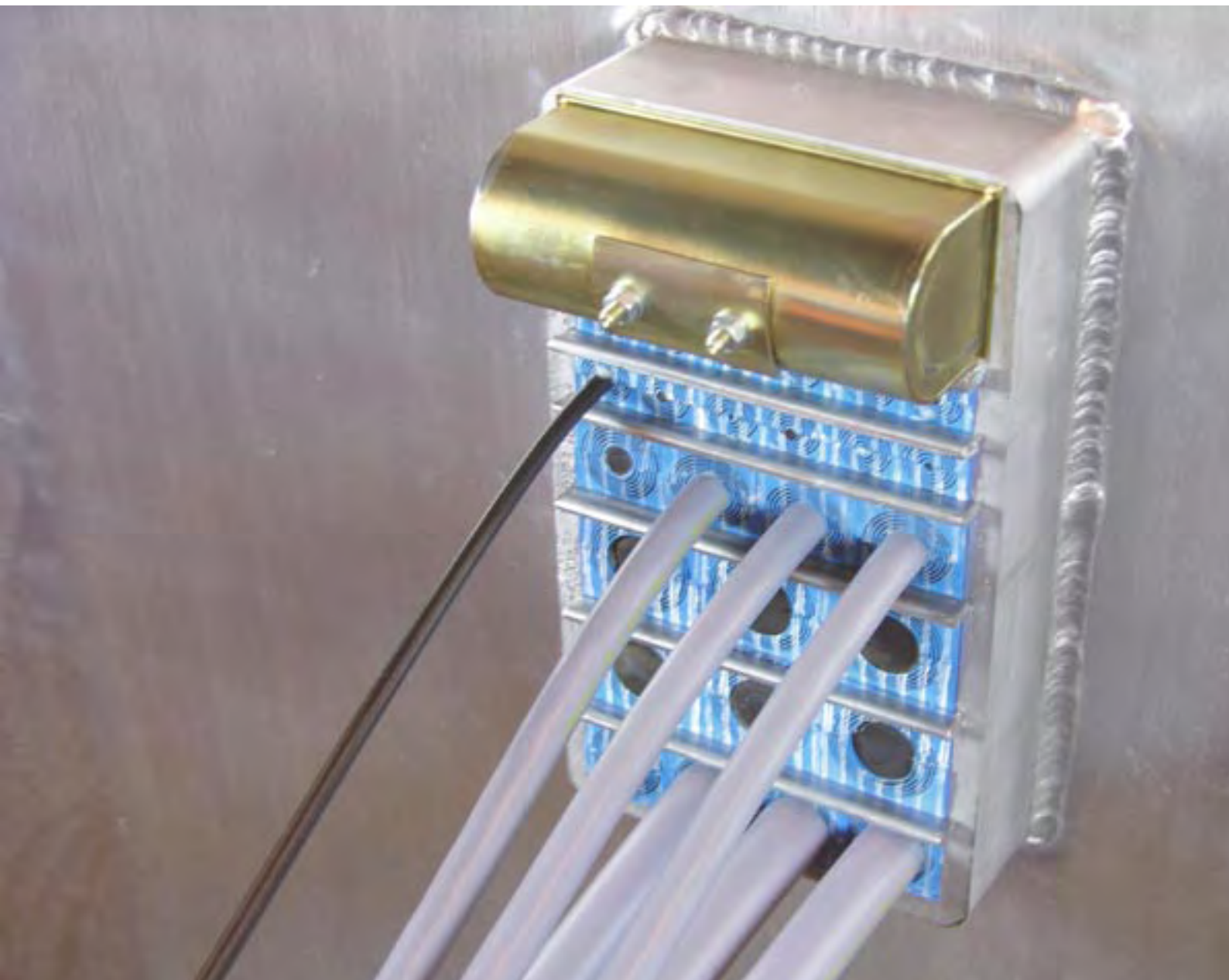

Cable and pipe
transit brochure for
EMC applications

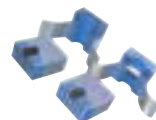

EMC seals with multidiameter technology for cables and pipes



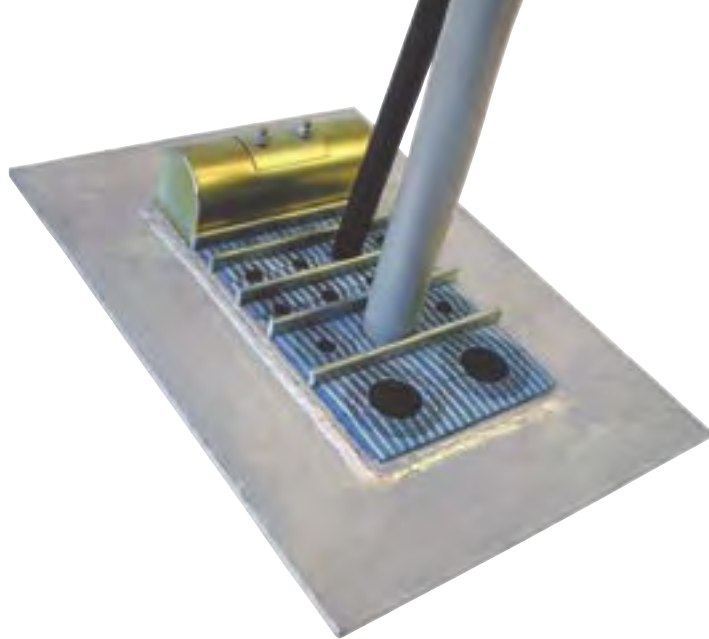

We Seal Your World

Roxtec's applications with multidiameter technology have set the standard for cable and pipe sealing throughout the world. This type of sealing creates added value for customers as well as more secure installations.

Roxtec sealing products provide a wide range of applications in the industry. With today's increasing demand for effective sealing solutions, Roxtec clearly stands out.

With focus on functionality, Roxtec continuously develops products. We are proud to say that our line of modular cable and pipe seals is the most extensive in the market, ensuring that you will find the most cost-efficient sealing solution for your needs.

Thanks to our subsidiaries, distributors and agents in more than 80 countries customers get easy access to support and quick deliveries. In addition, Roxtec in Sweden has an advanced commercial support and technical service department that assists our partners and customers. ■

This is EMC

EMC translates to electromagnetic compatibility, i.e. the ability of electrical or electronic devices to function properly in their intended electromagnetic environment, and without introducing unwanted electromagnetic disturbance in that environment.

EMC is a measure of quality. It tells how well a device can cooperate with other devices, electrically. There are, of course, a number of international standards dealing with, and defining the various aspects of EMC.

Electromagnetic disturbance

Electromagnetic energy is transmitted by electrically conductive materials, or by electromagnetic waves in space ("in the air"). Conductive

materials are usually metals in cables, cable screens and enclosures. Many liquids are conductive. Water is more or less conductive, unless it has been distilled. Salt water and rain water in coastal, industrial or urban areas are conductive. Electromagnetic disturbance is any electromagnetic phenomenon, which may degrade the performance of a device, equipment or system, or adversely affect living or inert matter. ■



The Roxtec EMC system

The Roxtec EMC product family is named after its intended purpose, which is to improve the electromagnetic compatibility between different electric and electronic devices.

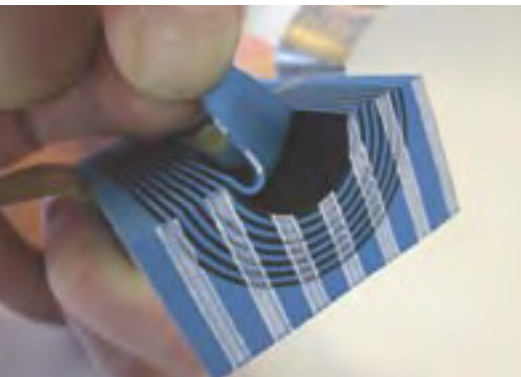

The system is a modular based cable and pipe transit for EMC applications as well as a mechanical penetration seal. It consists of a metal frame, which is installed in a partition or wall, Roxtec EMC modules and a compression unit. The seal has a dual function. It prevents unwanted electromagnetic fields, as well as foreign matter, from leaking either way through the feedthrough.

System components

The frames come in different shapes and sizes and can be incorporated into the construction either during the building process or after. A good connection to the ground system is vital. The frames make openings for cables and pipes passing through walls and partitions. The cables and pipes are

sealed inside the frame by inserting Roxtec EMC modules. The Roxtec wedge is then fitted and tightened to add compression and complete the seal.

Multidiameter™ technology

The big success of the system is due to the fact that one sealing module can handle a large number of different cable and pipe diameters. Roxtec's unique multidiameter technique allows the module to be adapted to any cable by peeling off consecutive layers from the center. Modifying a Roxtec EMC module in such a way is straightforward and quite easy, and it ensures a very tight seal against hazards such as fire, liquids, gases, explosion, rodents, dust and dirt. The multidiameter technology is a unique



invention from Roxtec International AB in Sweden, and it makes the Roxtec EMC system perfectly adapted to the market's request for simple cable transit modifications.

Future included

The transits can be reopened and closed again whenever alterations are needed, e.g. when exchanging cables or adding new ones. Spare capacity in the form of extra modules can be included in the system to be used at a later date. The multidiameter layers ensure a perfect fit every time.

Qualified protection

Once all modules are inserted and the transit is complete, it seals the penetration as well as protects any attached equipment from induced electromagnetic disturbances trying

to pass in any direction.

The Roxtec EMC products has been tested of several authorities. The most common test types that have been performed on Roxtec EMC products are shielded attenuation tests according to standard EN 50 147-1:1996 §5.2.2. and transfer impedance tests according to standard VG95373.

Information about tests for other environmental hazards than EMC can be found in catalogs for standard products. ■

EMC buzzwords



EMI

Electromagnetic interference is the degradation of the performance of equipment, a transmission channel or a system, caused by an electromagnetic disturbance. The English words interference and disturbance are often used indiscriminately, resulting in the terms EMI and Electromagnetic disturbance often being mixed or confused.

EMC, a two-sided matter

Electrical devices in general, and electronics in particular, are more or less sensitive to electromagnetic disturbance. All such devices are also sources of electromagnetic disturbance. Thus EMC, electromagnetic compatibility, is a two-sided matter. On one hand, the

device must have sufficient resistance to electromagnetic disturbance. On the other hand, it must not in turn generate electromagnetic disturbance, which may disturb the operation of other devices.

Waste by air

In plain English, electromagnetic disturbance is the same as electromagnetic waste, whether it arrives via air, as for example radio signals, or via cables.

Visualize electromagnetic disturbance

One way of visualizing electromagnetic disturbance is to think of it as noise. Ordinary background noise affects your ability to hear

what another person is saying. Low levels of background noise are usually acceptable, moderate levels are distracting and annoying. High noise levels make you miss the real message. Electromagnetic disturbance is a side effect of operating electric or electronic devices. However, electromagnetic disturbance can also be generated on purpose. This is done in "electronic warfare", where the purpose is to cause a disturbance, malfunction or even destruction of the opponent's equipment. A popular word for generating such disturbances is "jamming".

RFI

Radio Frequency Interference is degradation of the reception of a



wanted signal caused by radio frequency disturbance. Subsequently radio frequency disturbance is undesired electromagnetic energy transmitted by radio waves, which are electromagnetic waves in the 3 kHz–300 GHz frequency range. The term RFI is also commonly applied to a radio frequency disturbance or an unwanted signal. Radio frequency disturbance is often used in a general sense, meaning radiation over a much wider frequency range than radio waves. The reason for this is historical. Radio engineers were the first to use the concept of radio frequency disturbance, but later electronic engineers realized that the same phenomenon also existed outside the radio frequencies. A more

modern expression, based on a wider definition, is electromagnetic disturbance.

Grounding

Screens protect the cables or electronics from electromagnetic disturbance. A cable screen is a conductive layer, surrounding the cable conductors. Its purpose is to eliminate or weaken the transfer of electromagnetic waves to and from the conductors. In order to be efficient, a screen must be able to carry currents generated by electromagnetic disturbance away from the cable. This is done by grounding the screen.

Grounding is a technique used for removing unwanted electromag-

netic energy from a screen and improving the damping of electromagnetic disturbance. Proper grounding is critical for obtaining good EMC properties, i.e. good protection from electromagnetic disturbance, and is a vital part of all electronic and electrical design.

Damping

Damping is the engineering term for weakening an electric signal, whether it is a useful signal or an electromagnetic disturbance. There is a mathematical relationship between the efficiency of grounding and the damping achieved, often expressed as unitless decibel (db). ■

Electromagnetic disturbance – sources and receptors

All electric and electronic equipment are sources of electromagnetic disturbance, which means they have the potential for causing problems in other devices.



Sources

Some of the most common sources of electromagnetic disturbance are radio transmitters of all kinds: radio, TV, radar equipment, electric power lines, electronic circuits, lamp dimmers, arc welders and electric motors. Electric storms and large solar flares are also significant sources of electromagnetic disturbance.

Receptors

Potential "victims" of electromagnetic disturbance are radio and TV receivers, appliances, computers and electronics. Sometimes the impact of electromagnetic disturbance is harmless or acceptable. On the other hand, problems of electromagnetic disturbance affecting aircraft, medical equipment, navigational equipment and signaling systems represent serious health and security hazards. ■

Problems caused by electromagnetic disturbance

Problems caused by electromagnetic disturbance are common in everyday life, but they are often difficult to identify.

Only occasionally there is an apparent relation between the problems and their cause. These are a few examples:

- When you get a buzzing sound in your car radio as you pass by under an electric power line.
- When you hear irritating noises in your telephone if there is a cell-phone close by.
- When the TV picture gets distorted when you operate a vacuum cleaner close to it.

Some problems caused by electromagnetic disturbance can be quite

hazardous. The following examples have all occurred in real life.

- Cell-phones have caused incidents involving the airbags and ABS systems in cars.
- Digital TV has interfered with the functioning of medical equipment.
- Cell-phones have interfered with the operation of PLC's, programmable logic devices, which are the backbone of process automation in most industries.
- Microwave ovens have been observed to disturb the communication of devices using the new Bluetooth technology.

- A cell-phone has put a wheelchair out of control.

A rather extreme form of destructive electromagnetic disturbance is the damage done by lightning strikes. Very high overvoltages or very strong electromagnetic fields cause the damage. Some real-life incidents involving serious electromagnetic disturbance problems are described in detail in the example section of this catalog.

360-degree connection

EMC products are vital components for achieving electromagnetic compatibility for electronic and electrical equipment housed in a shielded volume – an equipment case or enclosure, a room or a building, a platform or a vessel.

The Roxtec EMC cable feedthrough acts as an integrated part of the shield surrounding the equipment. The shield represents a barrier to incoming or outgoing electromagnetic energy, whether it is transmitted as radio frequency waves or via cable screens.

Catch

In a Roxtec EMC cable feedthrough, the undesired electromagnetic energy is picked up by the low impedance foil surrounding each cable screen, or by the conductive rubber layer which covers the entire cross section of modules in a level, which is perpendicular to the individual cable inlets.

Divert

The electromagnetic energy is diverted to ground via a grounded metallic frame, which is part of the Roxtec EMC system. The reason for grounding each cable screen

around its perimeter is to eliminate the influence of inductance at the connection point with the screen. An inductance at the connection point would create frequency dependent impedance, which would spoil the effect of grounding, especially at high frequencies. The 360-degree screen connection completely eliminates any inductance.

Damp

Inductance is a term for a part of the resistance (impedance) between two points in an alternating current (AC) circuit that depends on changes in current intensity in an electric current circuit. The damping efficiency of the electromagnetic disturbances depends on the design and quality of the grounding system. The damping at high frequencies, 100 kHz–1 GHz, also depends on the number of cables passing through the cable feedthrough. ■



How it works

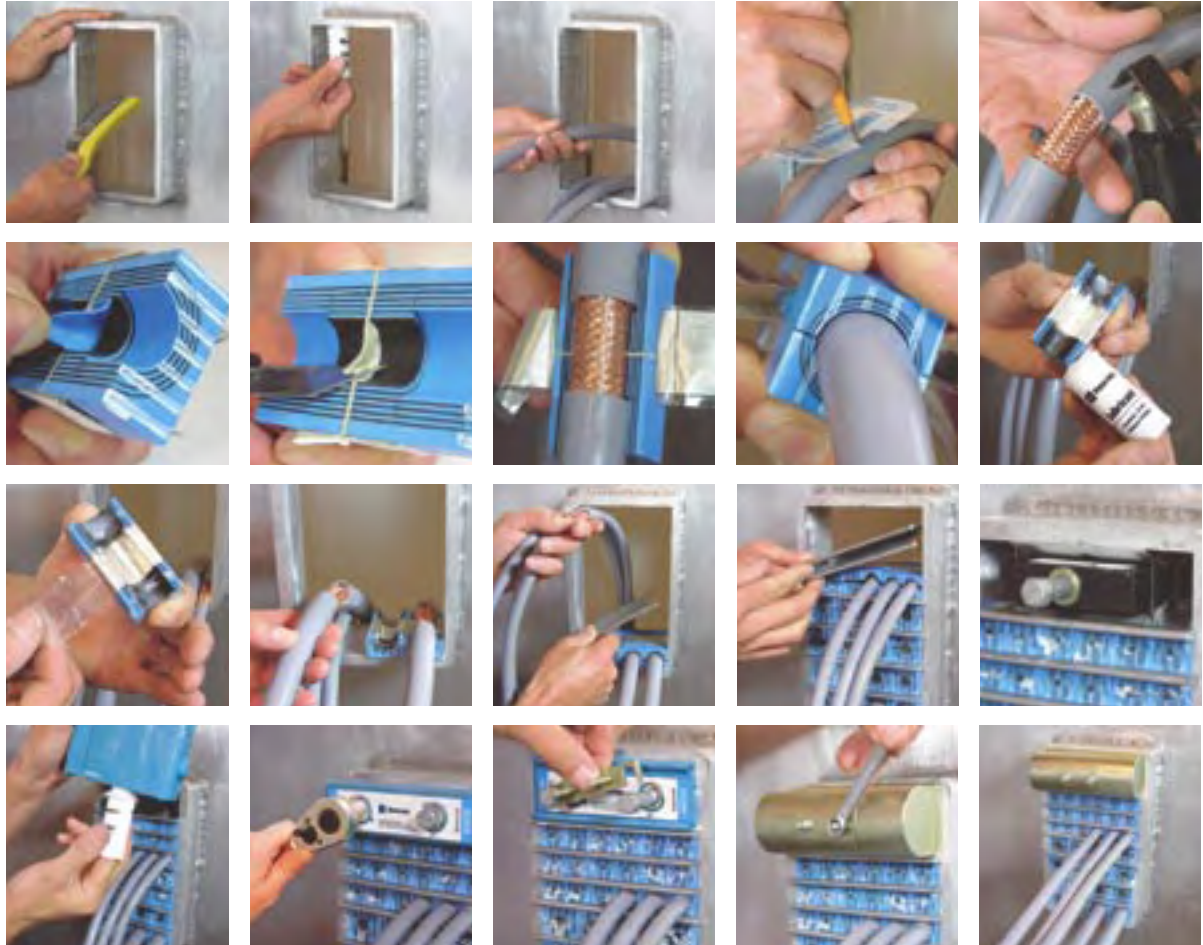

- Install the frame and route the cables.
- Mark out and remove the cable sheath, to expose the braided screen.
- Adapt the modules, by peeling of layers, to fit the cables.
- Lubricate the modules, except on the foil.
- Remove the plastic protection from the foil.
- Fill the frame with modules, and place a stayplate on every row of modules. If necessary, precompress the modules before inserting the lubricated wedge.
- Tighten the bolts on the wedge until stop.
- Finally, attach the ES cover to ensure full electromagnetic shielding capacity of the seal.

ES or PE protection

The electromagnetic protection provided by the Roxtec EMC feedthroughs has two components, each taking care of its own particular type of disturbance.

Roxtec EMC feedthroughs consist of an electrically conductive steel frame sealed by either ES or PE modules. The modules enable protection against unwanted electromagnetic energy carried by currents in the cable screen and shunt them to ground (ES and PE). ES modules further protect against unwanted "airborne" electromagnetic energy, thanks to an electrically conductive rubber material inside the modules.

Roxtec ES modules

The Roxtec ES module (electromagnetic shielding) marked with white stripes, consists of two identical halves, which are brought together to form a single unit when installed. Cylindrical, concentric layers of rubber make up the center of the module, they are peeled in order to make a tight fit to the cable. The cylindrical rubber layers are subdivided into four parts,

where the parts closest to the entry and exit points of the cable are peeled off to make a tight fit to the mantle of the cable. This part constitutes mechanical sealing that protects from leakage of e.g. water and gas (non-electromagnetic protection).

Conductive rubber

Through the center of the module, perpendicular to the cylindrical rubber layers, runs a layer of conductive rubber. This layer is the same size as the face of the module, and acts as a shield for airborne electromagnetic disturbances.

Conductive foil

The layers of the inner parts are peeled off to make a tight fit to the cable screen. A conductive, low impedance foil is wrapped all around the module, and is extended to cover 360 degrees around the cable screen. The low impedance

foil is in permanent contact with the conductive rubber and the cable screen. It also connects all the modules in the feedthrough together. The modules are installed in a metal frame, which is connected to ground. The foil leads the disturbances that are caught by the conductive rubber screen and the cable screen, through the frame down to ground.

Roxtec PE modules

The Roxtec PE modules (Potential Equalization) are marked with black stripes and used when only potential equalization or grounding is of importance. PE modules, as ES modules, consist of concentric layers and conductive foil but do not have a layer of conductive rubber. Even though there are no shielding screen inside the PE module there will still be some shielding effectiveness due to the conductive foil. The effect of the electromag-

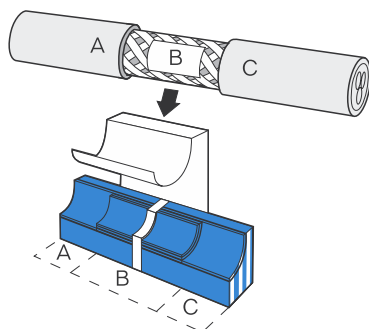

Cross-section of a Roxtec RM ES module.

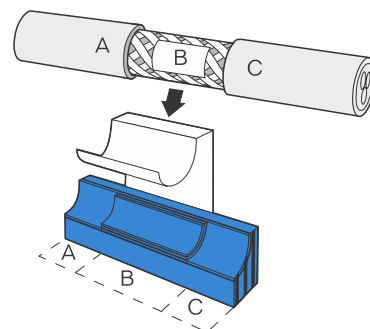

Cross-section of a Roxtec RM PE module.

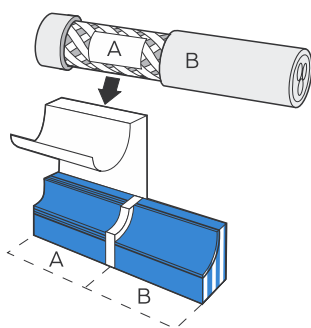

Cross-section of a Roxtec RM ES B module.

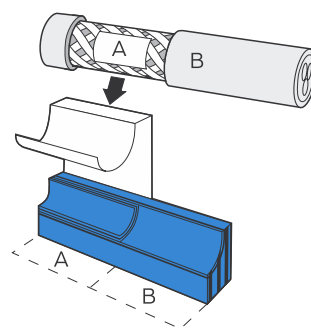

Cross-section of a Roxtec RM PE B module.

netic shielding will be weaker with PE modules.

Roxtec EMC module groups

Roxtec EMC modules (ES and PE) can be divided into groups: RM – Regular Modules and CM – Compact Modules.

Roxtec RM modules

Roxtec RM modules are used when higher performance is needed for protection against hazards as fire, liquid and gas pressure, explosion, etc. The frames that are used with RM modules are 60 mm in depth. Those frame types are: Roxtec S, SF, G and R. A compression unit (Roxtec Wedge) is necessary for those frames, except the R frame, in order to achieve a tight seal. The wedge cover ES is used on top of the compression unit in order to achieve a complete shielding effect. The RM modules are also available in a B version. B stands for back

and means that the conductive foil/rubber is placed on one end of the module. RM ES B or RM PE B modules are used where only one side has to be protected from hazards such as fire, pressure, explosion etc. Those modules are even easier to install.

Roxtec CM modules

CM modules are used in frames for cabinets and enclosure applications. They are also available in two version; CM ES and CM PE. The depth of the modules is 40 mm. Available Roxtec frames are: CF 8 EMC, CF 32 EMC and CF 16 EMC.

Roxtec Round Single Seals

Besides the Roxtec system with EMC modules, there are also seals for single cable or pipe entries in EMC versions – the Roxtec RS EMC seals. The principle is the same as for the modules except

that it is a single round seal that has to be installed in a grounded pipe or sleeve. The RS EMC seals are also available in two versions; Roxtec RS ES and RS PE. ■

Modules Types

Table of Roxtec EMC modules

RM ES	Regular Module Electromagnetic Shielding
RM ES B	Regular Module Electromagnetic Shielding Back
RM PE	Regular Module Potential Equalization
RM PE B	Regular Module Potential Equalization Back
CM ES	Compact Module Electromagnetic Shielding
CM PE	Compact Module Potential Equalization

Roxtec EMC system test results

Surface transfer impedance

Impedance [mΩ]

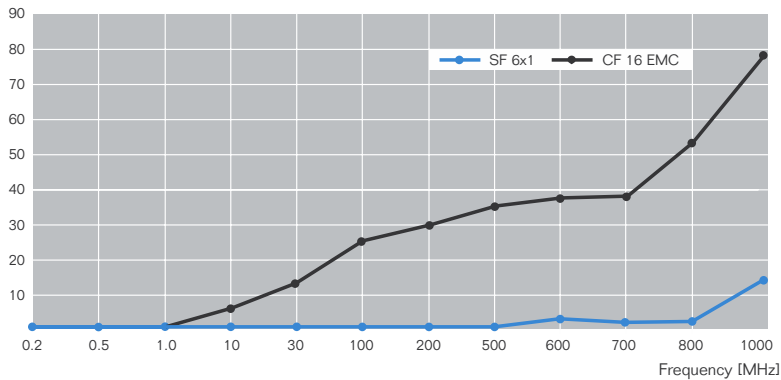

An example of a measurement of surface transfer impedance between conductive foil in the Roxtec RM PE modules and the frame. The test was performed according to standard: VG95373, part 15

Shielded attenuation measurement

Attenuation [dB]

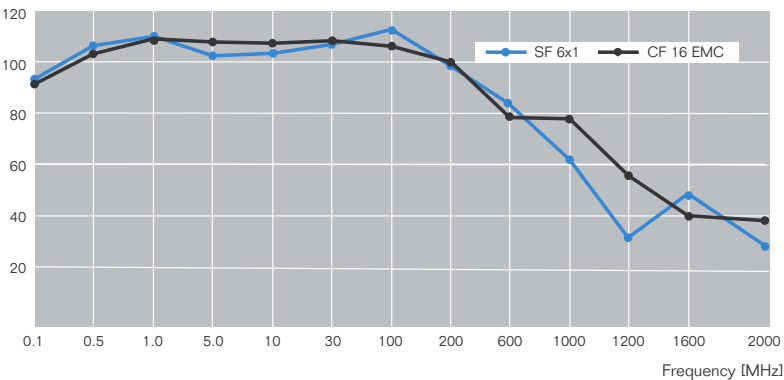

An example of a measurement of shielding effectiveness for Roxtec EMC frames with Roxtec RM ES modules, without cables. The test was performed according to standard: EN 50 147-1:1996 §5.2.2.

Cable selection

To achieve high EMC performance, the choice of cables is of utmost importance.

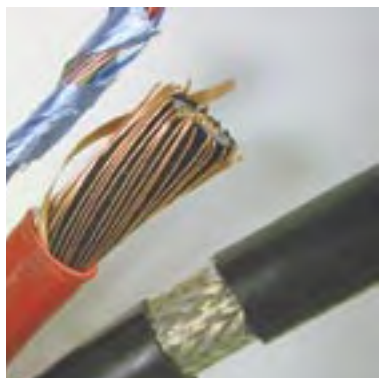

The cable must have a cable screen, and it should be dense. If the screen is not dense enough the electromagnetic disturbance may leak through to the cable conductors and lead the disturbance to the protected area. The best cables for EMC applications are those that have a plaited or homogeneous cable screen. Some cables have a cable screen made of metallic foil covered on one side with plastic film and wrapped around the

conductors. If this plastic film is facing to the outside of the cable, there will be no electric connection between the screen and the modules. These kinds of cables are not suitable for usage in the Roxtec EMC system. Another issue is the mechanical characteristics of the cables. If a cable transit must protect from both electromagnetic interference and water or gas leakage, the cables in it must be able to maintain their physical shape. ■

EMC dictionary

Conductive

An ability of a matter to conduct an electric current.

EMC

Electromagnetic compatibility. The ability of equipment or a system to function in a satisfactory manner in its electromagnetic environment, without introducing intolerable electromagnetic disturbances to anything else in that environment.

EMI

Electromagnetic interference. Degradation of the performance of equipment, a transmission channel or a system, caused by an electromagnetic disturbance.

Electromagnetic disturbance

Any electromagnetic phenomenon, which may degrade the performance of a device, equipment or a system, or adversely affect living or inert matter.

Ground

1. Return path for electrical current
2. Voltage reference

Grounding

Methods or technologies for achieving well-defined current return paths and for keeping stable reference voltages.

Impedance

A term for the total resistance between two points in an alternating current (AC) circuit.

Inductance

A term for a part of the resistance (impedance) between two points in an AC circuit that depends on changes in current intensity in an electric current circuit.

RFI

Radio frequency interference. Degradation of the reception of a wanted signal caused by radio frequency disturbance.

Shield

Conductive layer which picks up electromagnetic disturbances.

Screen

In cables, conductive layer which is used to reduce the penetration of an electromagnetic field into an assigned region.

Signal reference

A node or conductor which is selected as a reference, but which does not necessarily have to be connected to a grounded chassis.

System ground

When a certain point in an electrical system is selected as the zero volt reference.

The Roxtec solution was born in an entrepreneurial spirit in 1990: a simple, adaptable seal that could solve the problems associated with cable and pipe penetrations. The rest is now history. Our transits has become the industry standard, and Roxtec is the largest supplier in the business. Roxtec is represented locally in all of the large marine and offshore markets, for example, China, South Korea, Japan, France, Italy, the United States, Norway and Singapore. ■



Roxtec International AB
Box 540, 371 23 Karlskrona, SWEDEN
PHONE +46.455.36 67 00, FAX +46.455.820 12
EMAIL info@roxtec.se, www.roxtec.com