



FLAMEPROOF TYPE Ex 'de' WELLGLASS LUMINAIRE

APPLICATIONS

- Zone 1 hazardous gass areas
- Zone 21 hazardous dust environments
- Chemical and pharmaceutical industries
- Offshore and marine applications
- Spray paint booths
- General purpose lighting
- Heli-deck perimeter marking

CERTIFICATION AND APPROVAL

ATEX Certificate No. SIRA04ATEX1220

IECEX Certificate No. IECEX SIR 04.0033

CE Ex II 2GD EEx de IIC T6*

Ambient temperature range from -50°C to +70°C

Ingress Protection to IP66 & IP67

* Refer to matrix for lamp, 'T' rating & orientation.

FEATURES AND BENEFITS

- Extreme ambient temperature range from -50°C to +70°C
- Spigot mount unit available (pictured above)
- Range of coloured glass options available
- Extensive range of lamps
- IECEx and ATEX Approved for gas and dust
- Lightweight and low profile construction
- Simple 'Slide-and-Lock' mounting
- Unique design eliminates exposed flame-path reducing maintenance and installation times
- Complies with CAP437 for Heli-deck platform lighting

ORDERING REFERENCE

Std. Cat Ref.	Wattage	Lamp Type	Lampholder	T Class	T °C (Dust)	Ambient °C
TI7D/050/HS	50W	HPS	E27	T4	111	61
TI7D/050/MV	50W	Mercury Vapour	E27	T4	105	55
TI7D/070/HS*	70W	HPS	E27	T4	111	61
TI7D/070/MH*	70W	Metal Halide	E27	T4	111	61
TI7D/080/MV	80W	Mercury Vapour	E27	T4	115	55
TI7D/100/MH*	100W	Available on special request - contact sales				
TI7D/125/MV	125W	Mercury Vapour	E27	T4	127	47
TI7D/150/HS	150W	HPS	E27	T3	122	47
			E27	T4	100	25
TI7D/200/GL	200W	GLS	E27	T4	128	63

*No ignitor option - lamp with internal ignitor required.

TECHNICAL SPECIFICATION

LAMP TYPES

50W & 70W SON 70W & 100W MBI
 50W, 80W & 125W MBF 200W Max GLS E27
 150W SON/T (White SON - E27 Cap only)

POWER SUPPLY

SON, MBI & MBF lamps: 220V, 230V, 240V & 250V,
 50Hz or 60Hz
 GLS: 250V max

POWER CONSUMPTION

50W SON = 60W 70W SON = 80W
 150W SON = 172W
 100W GLS = 100W 200W GLS = 200W
 80W MBF = 90W 125W MBF = 140W
 70W MBI = 80W 100W MBI = 120W

POWER FACTOR

Better than 0.85 for High Intensity Discharge Luminaire

TERMINALS

Up to 6mm². Terminals for live, neutral, earth, and loop in / out are provided. Internally earthed. External earth provided.

CABLE ENTRIES

Two M20 x 1.5 entries as standard. Pole-mount has 1 x M20 entry as standard. Other cable entries available on request. An approved EEx 'e' cable gland must be used which also maintains the IP rating.

TEMPERATURE

Refer to the matrix above for ambient temperature range and 'T' ratings. The VL147 is approved and certified for safe use at temperatures down to -50°C. Due to the current lamp technology Victor Products can't give any guarantee on lamp performance at these extreme low temperatures. Contact Victor Lighting technical department for further details.

MATERIALS

Main body - Marine grade aluminium alloy with full epoxy powder coating as standard.
 Borosilicate glass.

WEIGHT

HID 9.0kg
 GLS 7.5kg

SUSPENSION

Mounting supplied with luminaire is for pendant operation suitable for two Ø 10mm fasteners on 275mm centres. Pole mount is for direct mounting to poles up to Ø 42mm. Optional stirrup mounting available for wall/directional applications.

OPTIONS - SUFFIX TO CATALOGUE REF.

- /220 220V
- /230 230V
- /60 60Hz
- /M25 M25 Entries
- /SE Spigot mounted
- /NI No igniter (70W and 100W only)
- /ABR Amber glass lens
- /BBR Blue glass lens
- /GBR Green glass lens
- /RBR Red glass lens
- /YBR Yellow glass lens

ACCESSORIES

Description

There are no accessories for this product

DIMENSIONS

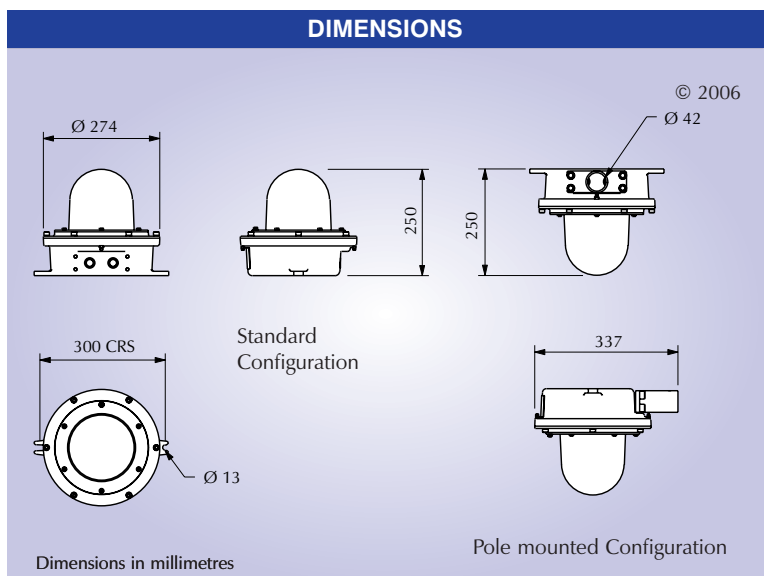

To calculate photometric values for lighting design, please use the free Victor "Lite Guide" software package. To request your copy, please contact your local Victor agent or use the request form on the website.